

# ETHERCAP Side Plugged

## Rotating data link

Datasheet

### Description

Rotating capacitive data link. Main characteristics:

- 100MB/s Ethernet interface suitable for real-time ethernet-based field buses.
- 22mm internal bore for the passage of pipes and/or cables.
- Industry standard M12 connections.
- High strength aluminum structure.
- IP54 permits wide range of uses.
- Standard M4 fixing holes.
- Status LEDs

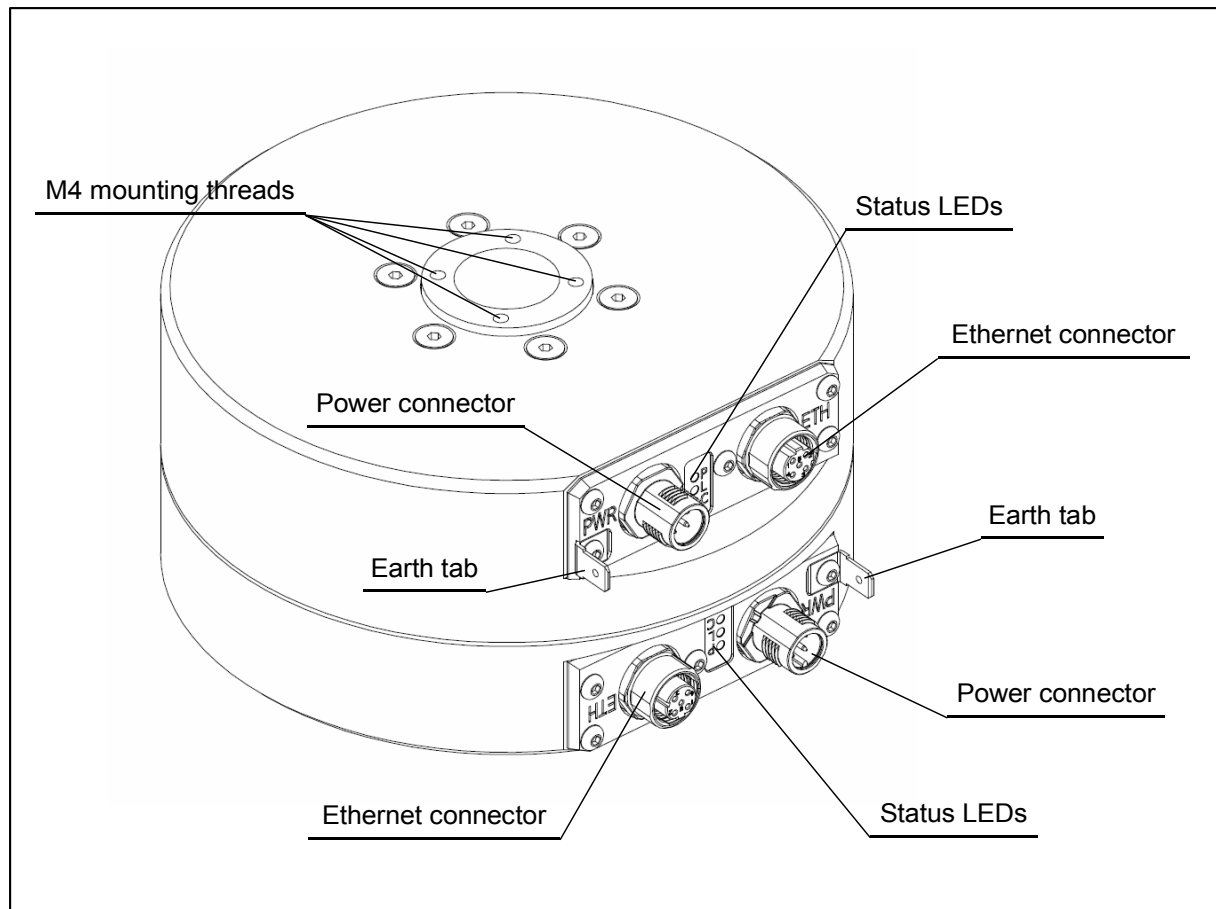

## Ordering informations

<b>Products</b>	<b>SMITEC part number</b>
Link module Ethercap Side Plugged	KZ010435
Field installable angled male M12 D coded connector for Ethernet connection (Phoenix Contact p/n 1521258)	EP200339
Field installable straight male M12 D coded connector for Ethernet connection (Phoenix Contact p/n 1543223)	EP200427
Field installable angled female M12 A coded connector for power connection (Phoenix Contact p/n 1681130)	EP200147
Field installable straight female M12 A coded connector for power connection (Phoenix Contact p/n 1543029)	EP200146

<b>Documentation</b>	<b>SMITEC part number</b>
Datasheet for KZ010435 (english)	DK400176

## Technical data

<b>General data</b>	
Housing dimensions w/o field connectors (width x height x depth)	150.2 mm x 150.2 mm x 74 mm
Shaft bore	22 mm
Mounting holes	8 x M4
Weight	1,8 kg
Permissible operating temperature	+5° to +55°C
Permissible storage and transport temperature	-40° to +70°C
Permissible humidity	10% to 95%, not condensing
Permissible air pressure (operation)	80 to 106 kPa (up to 2000 m above sea level)
Permissible air pressure (storage and transport)	70 to 106 kPa (up to 3000 m above sea level)
Degree of protection	IP54 according to IEC 60529
Functional earth connection	Dedicated 6,35mm faston tab on each half casing
Module state visual indicators	Status LEDs on each half casing front panel
International standard compliance	IEC61132-2 (Programmable controllers)

<b>Power supply</b>	
Module power supply	2 x 24 VDC (20.4 ÷ 28.8 VDC according to IEC 61131-2)
Power supply connectors	Male M12 A coded connectors

<b>Fieldbus interface</b>	
Fieldbus type	Ethernet 100BASE-T IEEE 802.3 compliant SERCOSIII™ compliant (Ethernet based)
Fieldbus connectors	Female M12 D coded connectors
Transmission speed	100 Mbps

## Introduction

This module allows to make a contactless fast data link between two revolving machinery parts.

Tested on high-speed real-time SERCOSIII™ protocol, it is suitable for Ethernet-based fieldbuses.

## Connections

The module has four connectors: two power connectors marked PWR and two data bus connectors marked ETH.

They are in couple arranged on a plate sited on each half casing, allowing an easy “plug and play” of the module, and also a fast replacement of a faulty unit (in the illustration is represented only one side of module).

The shells of connectors are electrically earthed and on PWR side is present a functional earth connection tab.

Data bus wiring should be done using standard CAT 5E Ethernet cable and M12 D coded connectors.

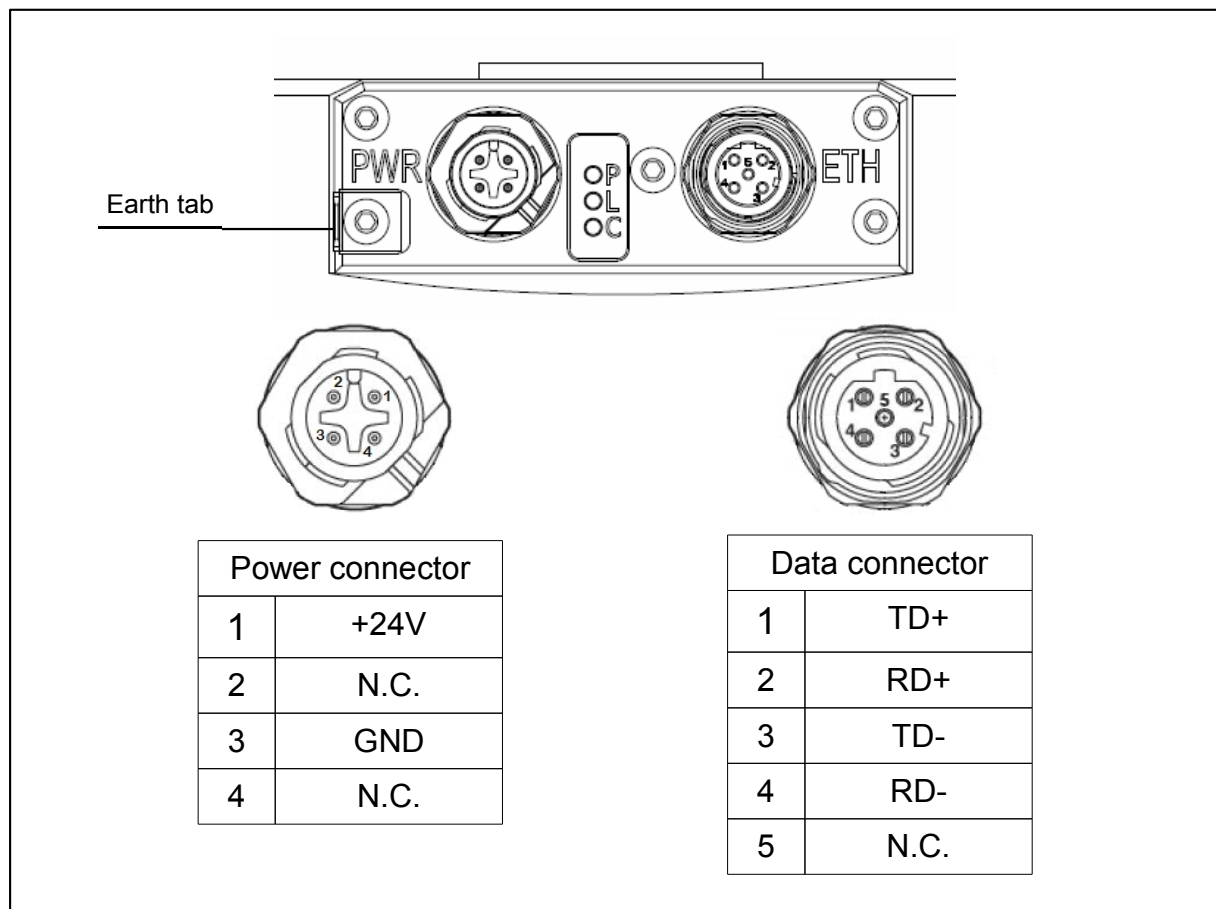

## Status LEDs

The six green status LEDs are sited between the two M12 connectors, three on each half of the module; every group of three LEDs have the same meaning but they are related to the half of module where they are placed.



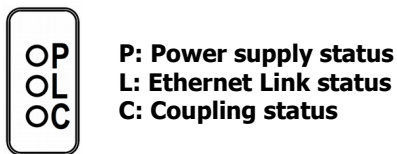

Their meaning is explained in the next diagrams:



Pictures legend:



Possible states when powered:

- 1  Power supply present  
Ethernet cable unplugged / no ethernet link  
No data from coupled disc
- 2  Power supply present  
Ethernet cable plugged, link established, but no communication  
No data from coupled disc
- 3  Power supply present  
Ethernet cable plugged, link established, communication in progress  
No data from coupled disc
- 4  Power supply present  
Ethernet cable plugged, link established, but no communication  
Data received from coupled disc
- 5  Power supply present  
Ethernet cable plugged, link established, communication in progress  
Data received from coupled disc

## Mechanical dimensions

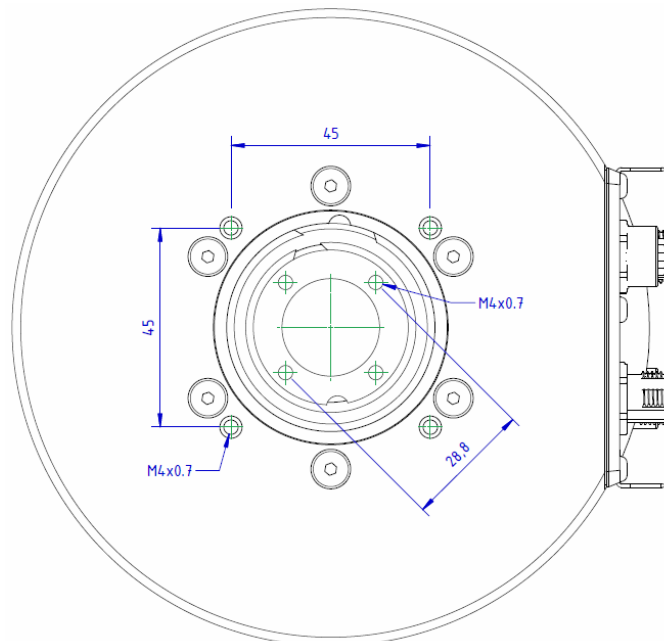
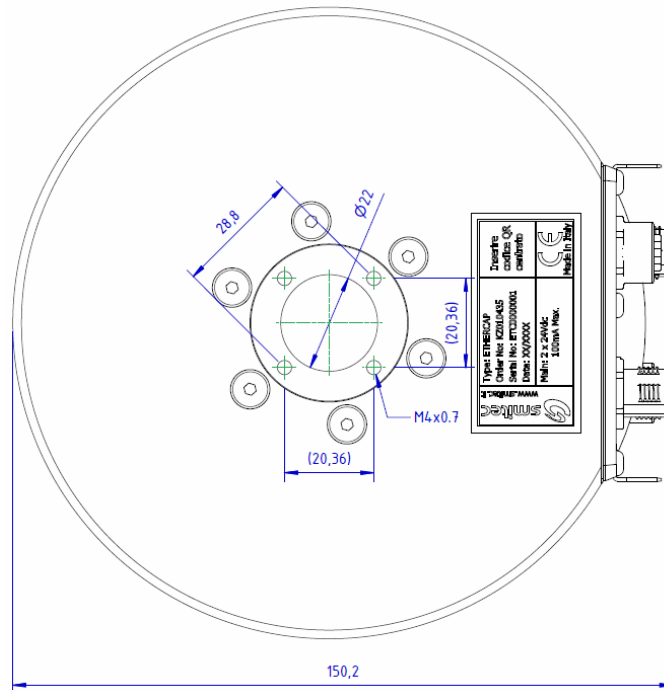

Upper and bottom views w/o field installable connectors

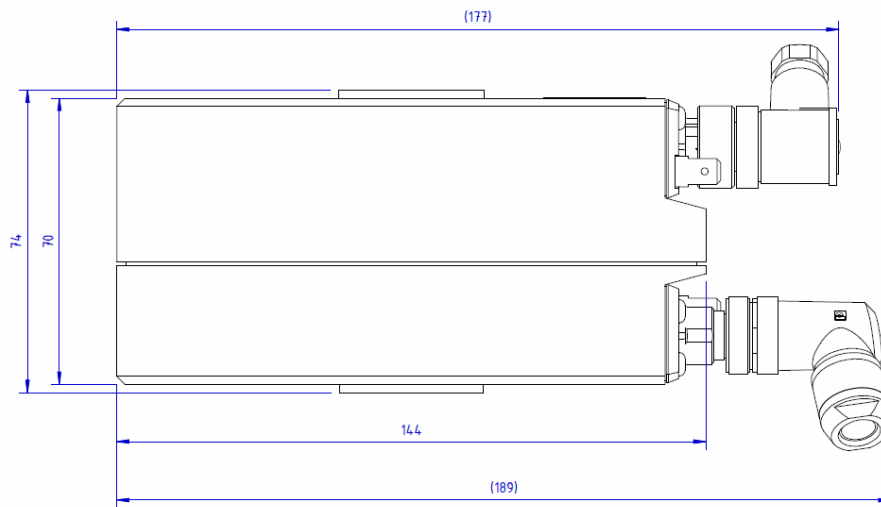

Side view with angled field installable connectors (for reference only)