

CVO A2

Module with 2 analog outputs

Datasheet

Description

Module with 2 digital analog outputs. Main characteristics:

- 2 analog outputs 0-10 V or 0-20 mA
- 12 bit resolution
- Load range (voltage outputs): 1 k Ω to ∞
- Load range (current outputs): 0 Ω to 600 Ω
- Status and diagnostic LEDs

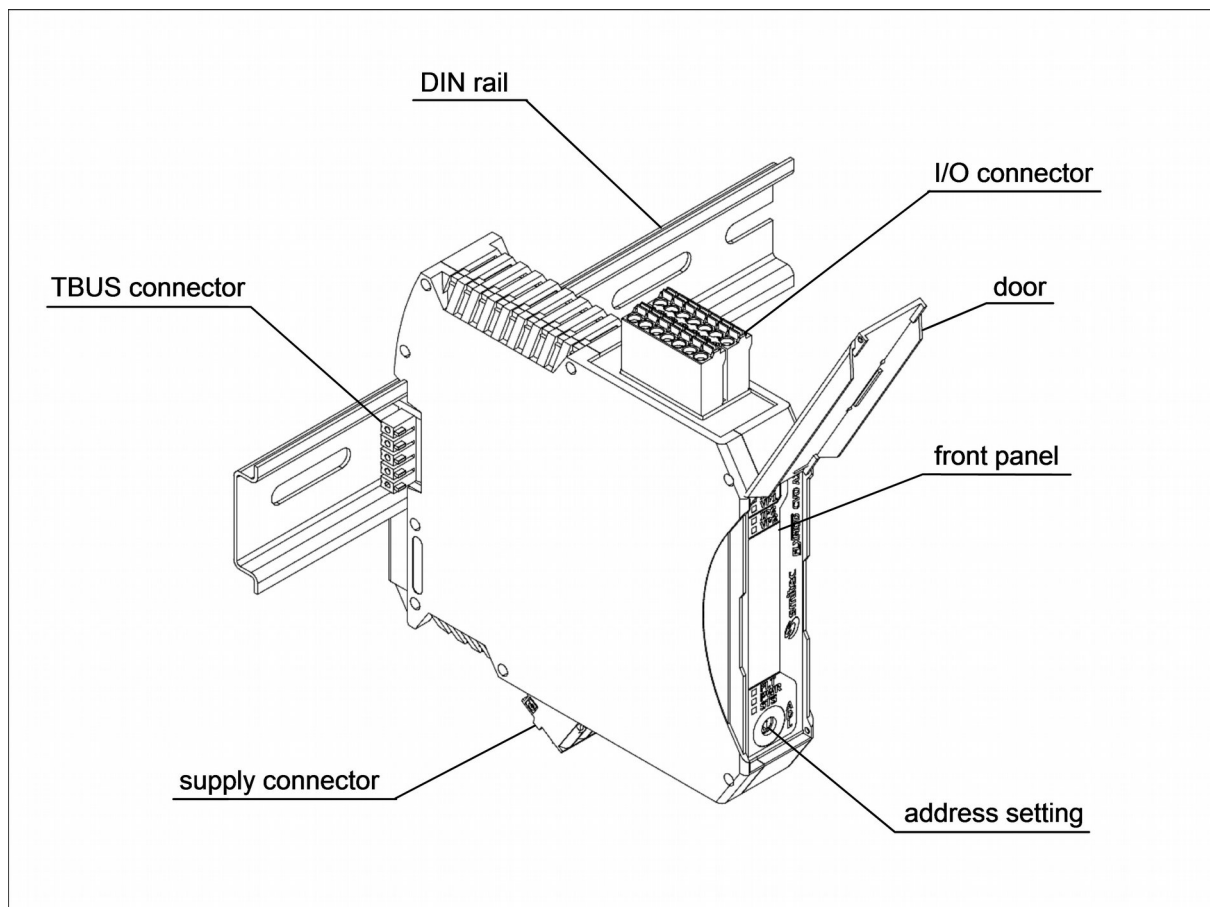

Ordering informations

Products	SMITEC part number
Module with 2 analog outputs, complete with accessories (power connector, outputs connector and TBUS connector)	KZ010205

Accessories	SMITEC part number
Power supply connector (Phoenix Contact p/n 1910377)	KF100009
I/O connector (Phoenix Contact p/n 1738856)	KF101049
TBUS connector (Phoenix Contact p/n 2713722)	KF101034
Power supply fuse (Littelfuse p/n 0452 002)	KD201035

Documentation	SMITEC part number
Installing instructions for CVO A2 (multilanguage)	DK400046
Datasheet for CVO A2 (english)	DK400070
FLXMOD system integration manual (english)	DK400076

Technical data

General data	
Housing dimensions (width x height x depth)	22.5 mm x 99.0 mm x 114.5 mm
Weight	98 g (without connectors), 117 g (with connectors)
Permissible operating temperature	+5° to +55°C
Permissible storage and transport temperature	-25° to +85°C
Permissible humidity	10% to 90%
Permissible air pressure (operation, storage and transport)	70 to 106 kPa (up to 3000 m above sea level)
Degree of protection	IP20 according to IEC 60529
Connection method for connectors	Spring cage terminals
Conductor cross-section (power connector)	0.2 to 2.5 mm ² (24 – 12 AWG)
Conductor cross-section (output connector)	0.2 to 1.5 mm ² (24 – 16 AWG)
Functional earth connection	To the DIN rail with spring contact
Mode state visual indicators	Fault (FLT) and status (STS) LED lamps

Power supply	
Main power supply V_m	24 V DC (-15% ÷ + 20% according to IEC 61131-2)
Maximum allowed ripple	5% of supply voltage (according to IEC 61131-2)
Current consumption from main supply	1.5 A max. (for external loads supply)
Supply overvoltage protection	Bidirectional Zener clamp ($V_z > 30$ V)
Supply reverse polarity protection	Protection diode, and safety fuse
Supply fuse	2 A, not replaceable by the user
Local bus power supply	5 V DC (from local bus)
Local bus supply protections	None
Power presence visual indicators	Green LED lamp, lighted if main supply is present (PWR)
Power load from local bus at 5V DC	Approx. 0,25W
Power load from local bus at 24V DC	Approx. 0,6W + 0,35W for each output at full load
Total power dissipation	Approx. 0,85W + 0,35W for each output at full load
Max. current on V_S pin	1.5 A max.

Analog outputs	
Number of outputs	2
Voltage output range	0-10 V
Current output range	0-20 mA
Digital resolution	12 bit
Voltage output permissible load	1 k Ω to ∞
Current output permissible load	0 Ω to 600 Ω
Voltage outputs total error at 25°C	$\pm 0.5\%$ of full scale range
Voltage outputs temperature drift	$< 0.01\%/^{\circ}\text{C}$ (referred to full scale range)
Current outputs total error at 25°C	$\pm 0.75\%$ of full scale range
Current outputs temperature drift	$< 0.02\%/^{\circ}\text{C}$ (referred to full scale range)
Voltage outputs settling time for full-range step	< 1 ms
Current outputs settling time for full-range step	< 1 ms
Outputs common potential isolation from GND	500 VAC, functional
Isolation between channels	none
Output state visual indicators	Two orange LED lamps for every input, switched on if output 0-10 V (VPx) or output 4-20 mA (IPx) is active

Interface	
Local bus	Proprietary FLXIO™
Module address setting	By rotary switch on front panel
Bus connections	By TBUS connectors on DIN rail
Interface circuitry protections	ESD protections
Level of ESD protection	± 8 kV (IEC 61000-4-2, contact discharge)

Connections

The module has two connectors: a power connector and an output connector. They allow easy “plug and play” of the module, and also a fast replacement of a faulty unit.

Power connector

The power connector is located on the bottom wall of the module. For the pinout, refer to the illustration.

Its function is to provide the supply for the I/O circuitry, whilst the CPU of the module is fed by the TBUS connector on the back of the unit.

Refer to the FLXMOD System Integration Manual for power connections topology.

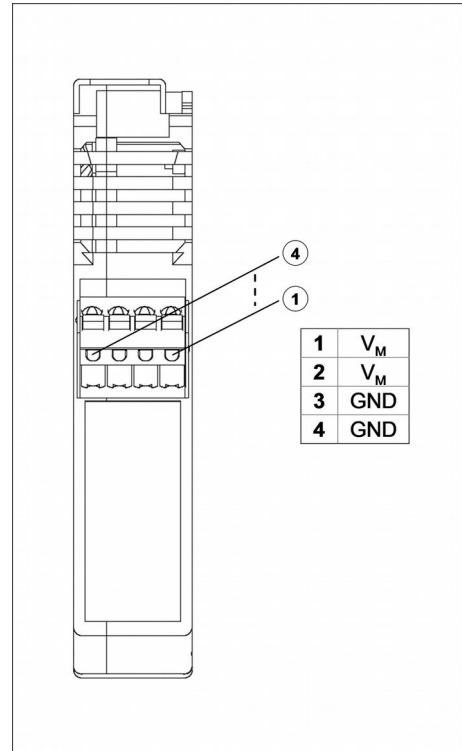

Output connector

Located on the upper side of the module, this connector (see illustration) permits the wiring of the output signals.

As you can see from the illustration, each row of the connector has the same pinout, to ease the wiring and prevent mistakes.

Connection notes

The connection scheme differs slightly, depending on the actuator's technology. More precisely, you have to use a different wiring for 4-wire, 3-wire and 2-wire actuators.

In the figure on the next page, you'll find the recommended wiring for these actuators. If the system should work in a noisy environment, the use of shielded wire is mandatory; the shield must be connected to the FE pin of the connector.

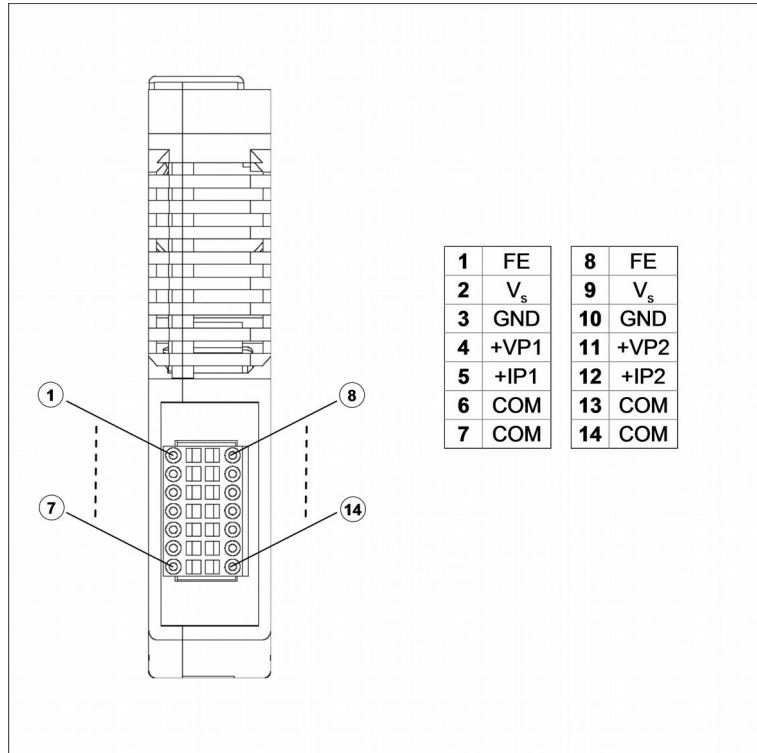

Warning: Use a cable with cross-section suited to the current involved. A wire smaller than necessary can cause risk of fire and unwanted voltage drops.



Warning: If the supply for an actuator is drawn from the output connector, be careful not to exceed the maximum current, or the internal fuse will blow. Refer to the module characteristics for fuse ratings.



Warning: If the actuator is fed by an external power supply unit, never exceed the isolation voltage quoted on module characteristics, or system failure will occur!



Warning: Supplying an actuator with an external power supply unit, be aware of signal degradation risk due to quickly varying common mode potentials. Whenever possible, the ground of the external power supply should be equipotential with the ground of the main power supply.

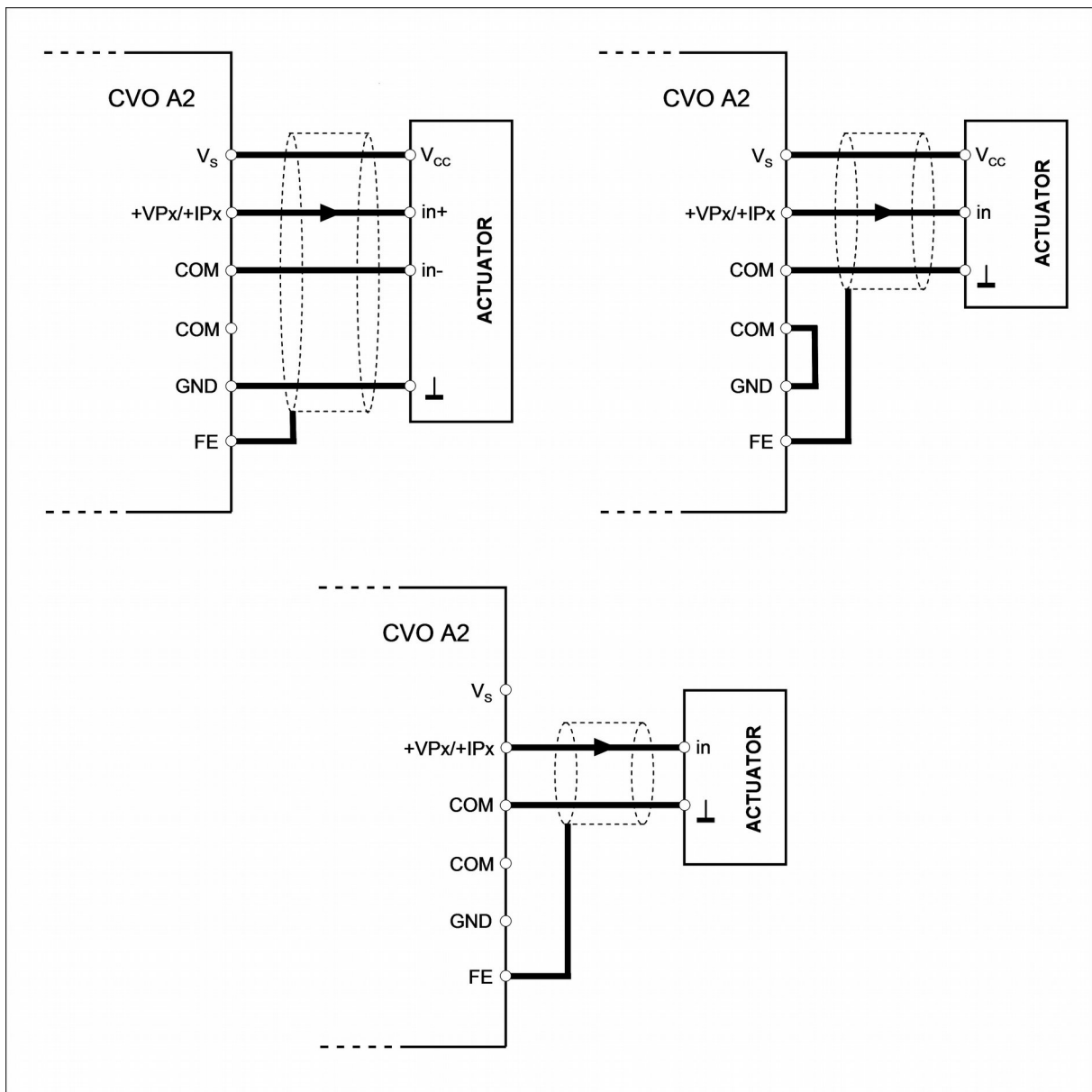

Recommended connection for actuators, using a 4-wire (above, on the left), 3-wire (above, on the right) and 2-wire (below) technique.

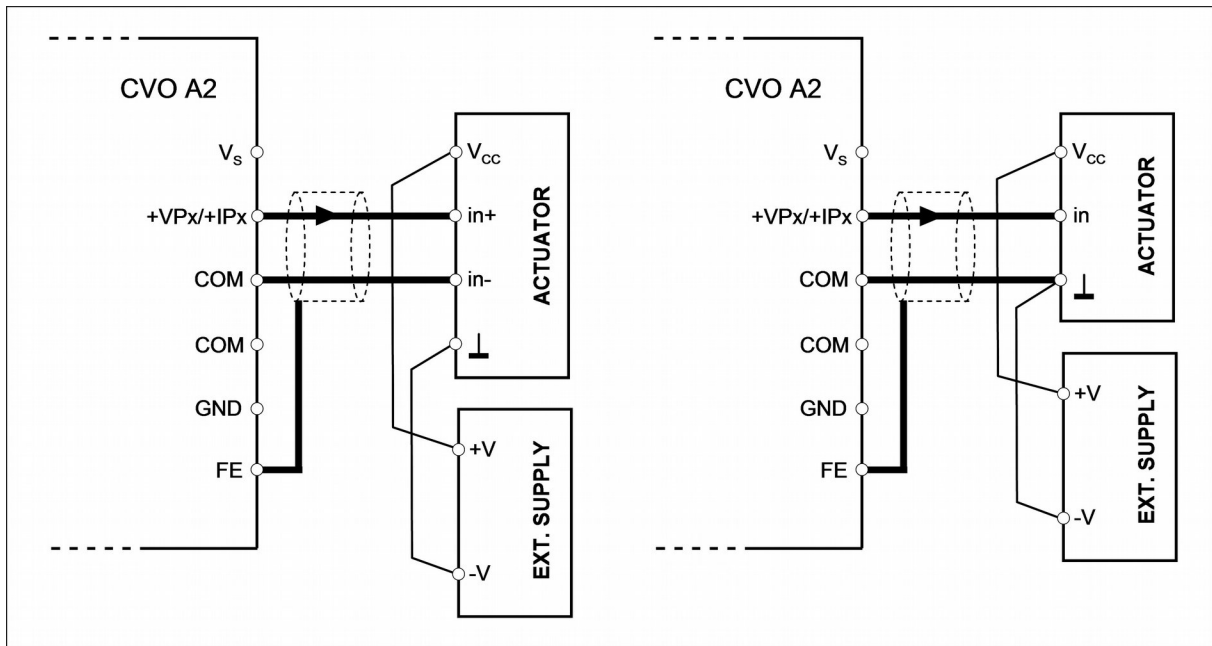

Recommended wiring for externally-fed actuators, having a differential (left) and single-ended (right) signal input.

Module addressing

Before operation you must set the address of the module by the rotary switch reachable from the front panel; the operation is easily done opening the transparent plastic cover and turning the rotor with a small bladed screwdriver.

The address determination is described in the FLXMOD System Integration Manual.

Diagnostic and status indicators

Each module is provided with a series of LED lamps on the front panel (see illustration), that indicates the status of the unit, the setting of every output (voltage or current) and a possible diagnostic warning. For the sake of clarity, different lamp colours are employed.

The green power (**PWR**) LED is lighted if the 24 V supply (V_M) is present and the internal fuse is not blown.

Self monitoring of supply voltage is also implemented to deliver a best self-diagnosis. The module switches in diagnostic error when $V_M > 30Vdc$ and when $V_M <$ of the value set up by the master module (low voltage check is disabled by default); this status is displayed by STS LED.

The **VP1** and **IP1** LEDs indicate that the output #1 is used as a voltage or current generator; their colour is orange. The **VP2** and **IP2** LEDs have the same function, regarding the output #2.

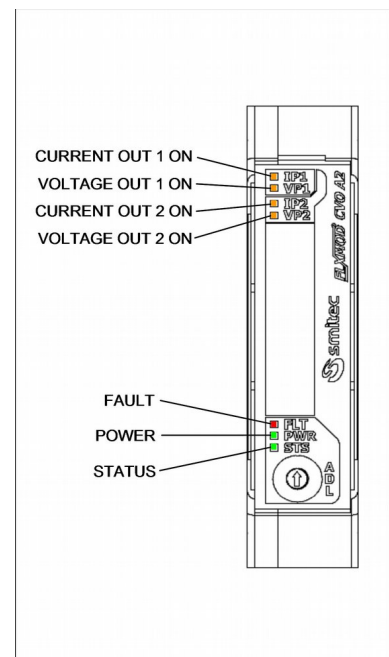

The status of the unit is indicated by both status (**STS**) and fault (**FLT**) LEDs; their behaviour is described in the following logic state chart. The exact cause of a diagnostic error can be read out by master module and the application software.

